

MAC-140/50

Profil İşleme Merkezi

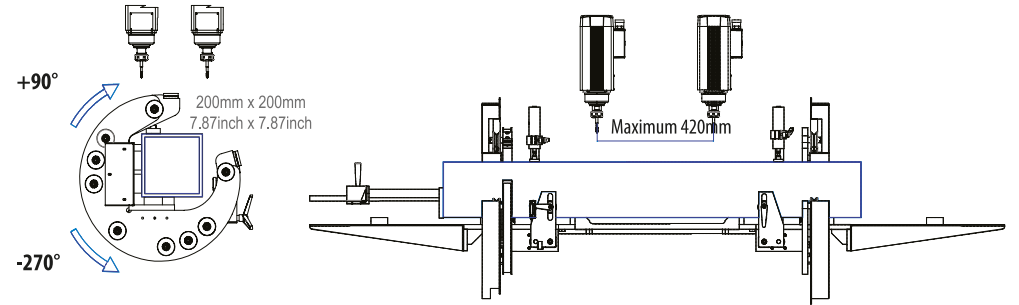

- PC kontrollü, 4 Eksen CNC Makinası.
- İşlenecek olan malzeme üzerinde aynı anda 3 eksen ile interpolasyon yapabilm.
- Servo eksenli dönen tabla.
- 4. Eksen yardımıyla, profilin tüm yüzeylerinden işleme imkanı.
- Alüminyum kapı, pencere ve cephe Profillerinde yüksek hassasiyette çalışabilme. (+/- 0,1mm)
- 2 yatay 2 dikey mengene ile Profilleri rijit bir şekilde sabitleyebilme.
- Makina bakımını kolaylaştıran merkezi yağlama sistemi.

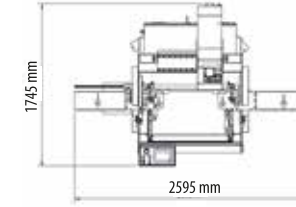
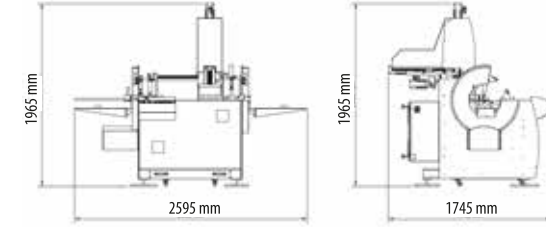

Teknik Özellikler

- Elektrik Değeri: 400V, 3-60 Hz
- Toplam Motor Gücü: 9 kW, 34A
- Hava Basıncı: 6-8 bar
- Hava Tüketimi: 80 l/Min (2.82 cfm)
- Spindle Motor: 4.5 kW (6.03 hp.)
- Spindle Hızı: 18.000 rpm
- Maksimum Profil Uzunluğu: 420 mm
- Maksimum Profil Geniřliđi: 200 mm (7.87 in.)
- Maksimum Profil Yüksekliđi: 200 mm (7.87 in.)
- Minimum Profil Yüksekliđi: 30 mm (1.18 in.)
- Makine Ađırlıđı: 850 kg (1,875 lbs.)



850 kg



6-8 bar



9 kW 34 A



H: 200mm

W: 200mm

L: 420mm