

## SC-110 Automatic Cutting Center

SAWS > SC-110

- Automatic and fast cutting of PVC profiles at different lengths.
- Loading of 10 profiles (max. 6500 mm length).
- Automatically feeds the profiles from the loading magazine, cuts at the desired lengths.
- The 500 mm. saw blade diameter enables cutting of wide profiles
- Able to make automatic cutting at all angles between 45° and 135° in 0,1° sensitivity via Servo motors.
- High performance industrial PC with Windows 10 Embedded operating systems and working between 0°C - 55°C without the need for a fan.
- All error messages can be monitored from the screen by the software developed by Haffner Machinery Software Department.
- The cut work pieces are automatically moved to off-loading station.
- The saw blade feed speed can be adjusted.
- Data transfer is available via network connection or USB interface.
- By online connection to the entire system, remote detection of malfunctions and maintenance is available.
- 15" touchscreen.
- Automatic conveyor belt system to transport scrap profiles to waste container.
- Full integration with various window and door production software.
- Barcode printer (AK 003)
- Extraction system (ES 024)

### CAPACITY

- Min 2600 meters / 8 hours
- Max. 2800 meters / 8 hours

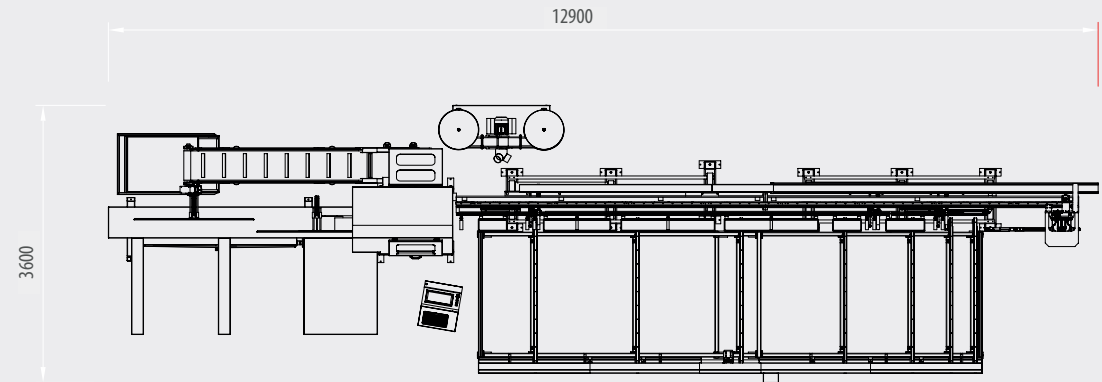
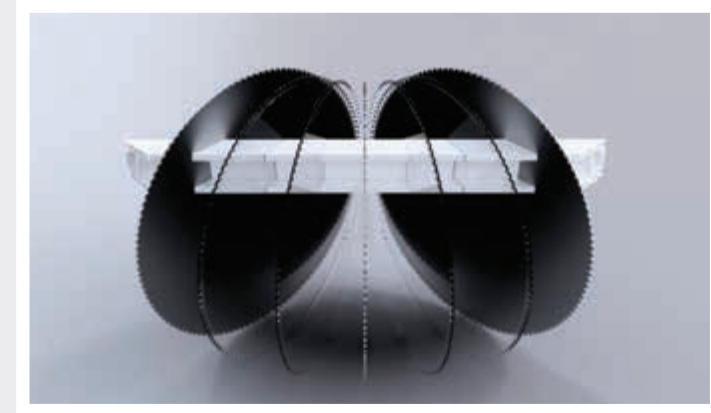

### Technical Features :

• Power Supply : 400 V, 3~ 50-60 Hz	• Machine Height: 1700 mm
• Total Power Output: 10 kW , 22 A	• Machine Length: 12900 mm
• Spindle Speed: 2800 rpm	• Machine Width: 3600 mm
• Max. Cutting Length: 4000 mm	• Machine Weight: 1600 kg
• Min. Cutting Length: 400 mm	
• Max. Raw Profile Length : 6500 mm	
• Air Pressure: 6-8 bar	

\* Please see the cutting diagram for the Min. and Max. profile size dimensions.

