

MS-300 Digital Measuring and Stop System

SAWS » MS-300

- Automatic positioning of the sliding stop to the desired length enables accurate cutting.
- The linear bearing system enables fast positioning.
- Digital automatic measuring is enabled by PLC control system with touch panel operating system.
- Data transfer is available via network connection or USB interface.
- Piece numbers, length dimensions, angular position and quantities can be programmed on the control panel. (2000 x 10 different data points can be stored)
- The conveyor height can be adjusted to match the cutting machine.
- Remote data transfer with Bluetooth communication.
- Compatible with TA-420, TA-133 and TA-141 saws.

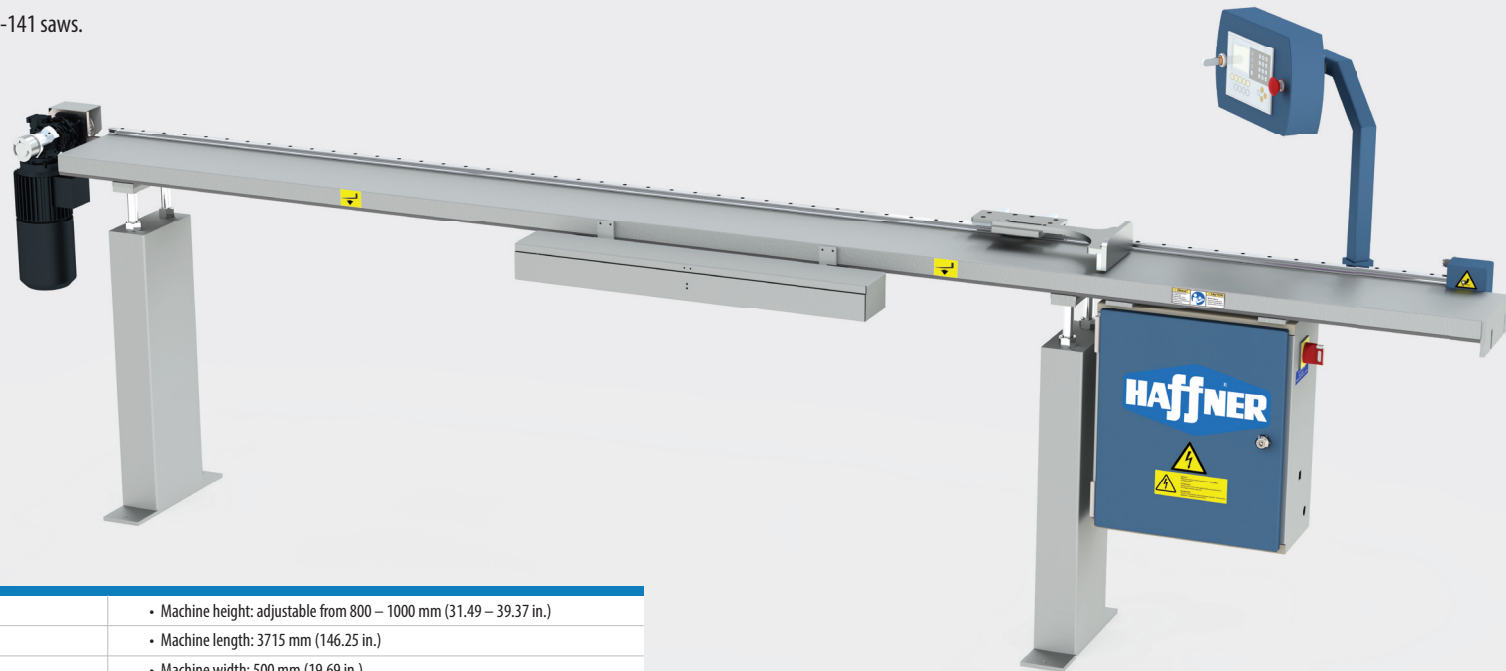

Technical Features :

• Power supply: 230V, 3 ~, 50/60 Hz	• Machine height: adjustable from 800 – 1000 mm (31.49 – 39.37 in.)
• Total Power Output: 0.37 kW	• Machine length: 3715 mm (146.25 in.)
• Maximum cutting length: 3000 mm (118.11 in.)	• Machine width: 500 mm (19.69 in.)
• Maximum profile width: 200 mm (7.87 in.)	• Machine weight: 150 kg (330 lbs.)